

Apraxia Lap Book

Follow the instructions on the following pages to assemble your lap book.

If you choose to use this file, you will need to glue your images down manually where appropriate.

We have used the editable lap book file to create the project shown in the photo instructions. Using the editable file allows you to insert photos and add text directly from your computer.

SLP Tip: Photos are best printed on white cardstock rather than colored. The images seem to disappear into colored paper.



Folding Your Lapbook

1. Use one 8" x 10" File Folder
2. Open and flatten the file folder.
3. Find the center of the right side of folder, and fold lengthwise on center line of right side.
4. Find the center of the left side of folder, and fold lengthwise on center line of left side. Sides should meet.



Front Cover Layout



Have your student draw a self portrait.

_____ 'S

SUPER

Speech

FOLDER

Blank writing area with a dashed border at the top and horizontal lines below.

MY NEXT SPEECH APPOINTMENT



Write a special note to your student under the flap!

Fill in your students' schedule here. Place a check to keep up with attendance.

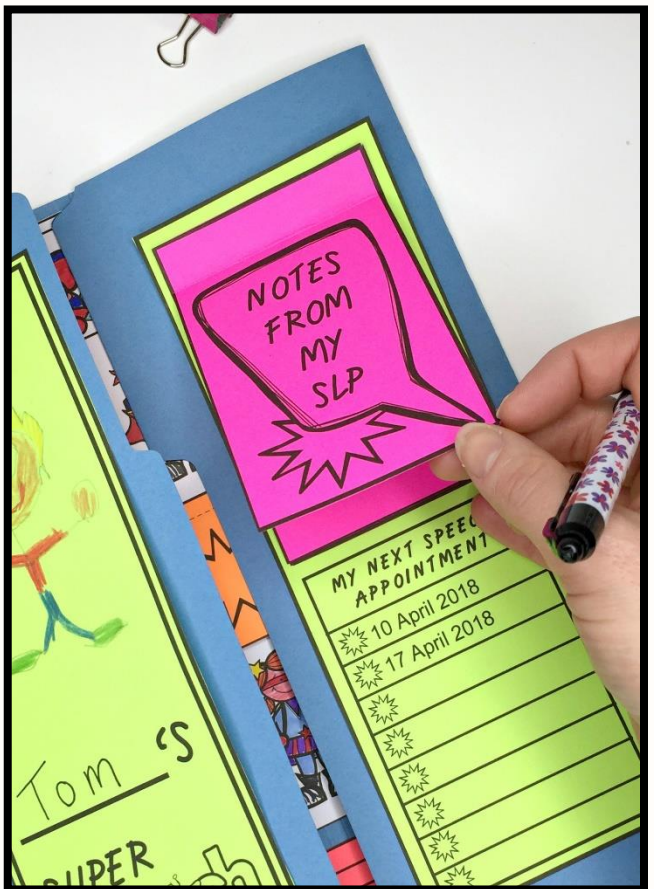
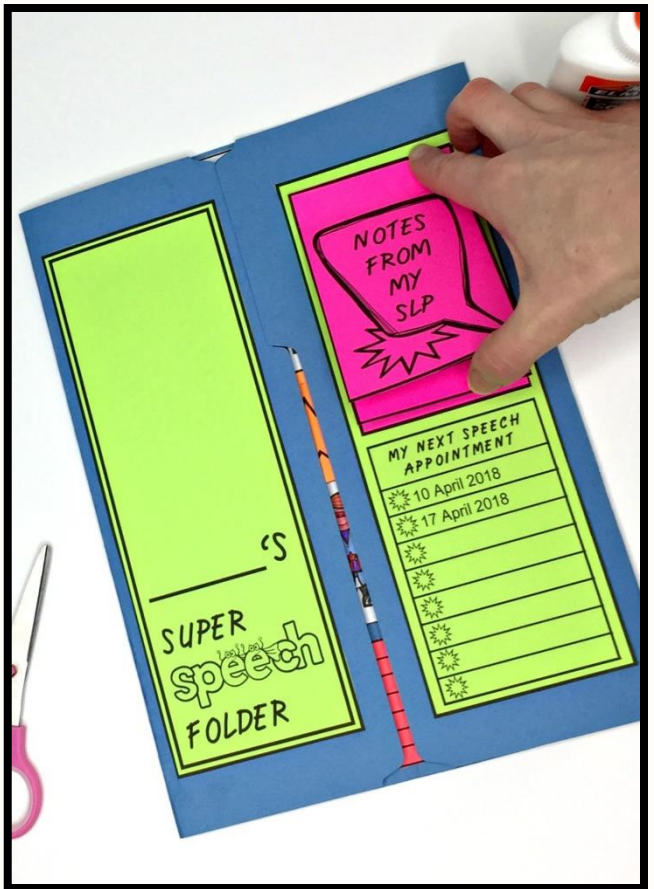
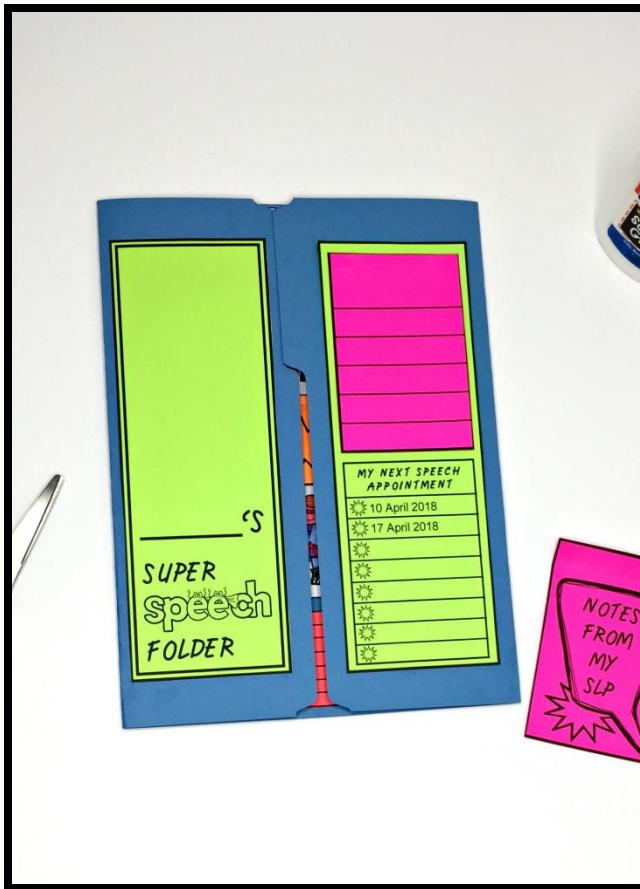

1. Glue Front Cover Right Flap Base Page flat onto the notebook.
2. Fold at the dotted line on the flaps found on this page.
3. Apply glue to the back side above the dotted line & secure one on top of the other on the indicated markers on base page. Secure the "Notes From My SLP" page last.
4. Use this page to send home special notes of encouragement to your student!

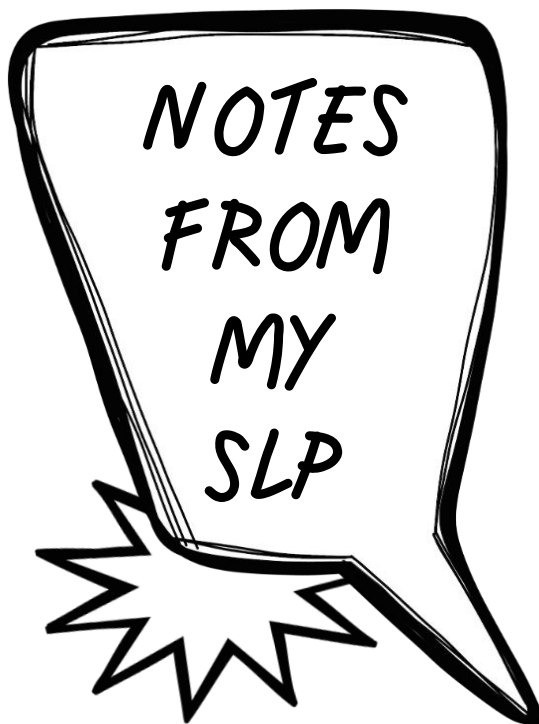

"My Favorite..." Flip Book Assembly Instructions:

1. Cut out each page and glue layer 1 into your notebook.
2. Taking care to align the top of each page, layer the pages by their numbers with 1 being the first page, then 2 on top, etc.
3. Select and cut out your character topper. Fold along the dotted line.



“My Favorite...” Flip Book Assembly Instructions:

4. Apply glue above the fold on the back side of the character topper and align with the top of your layered pages using the dotted line as a guide. Stick into notebook to create the top page of your flip book.
5. Insert your student's photo inside of the frame and secure into notebook above the flip book.
6. This activity also works great as a take-home review flipbook. Print the pages on durable cardstock and cut. Using the dotted lines as a guide, layer the pages & staple to create your booklet.



3 Apply glue above dotted line only.

2 Apply glue above dotted line only.

1 Apply glue above dotted line only.

5 Apply glue above dotted line only.

4 Apply glue above dotted line only.

Insert your student's photo inside of the frame and secure into notebook.

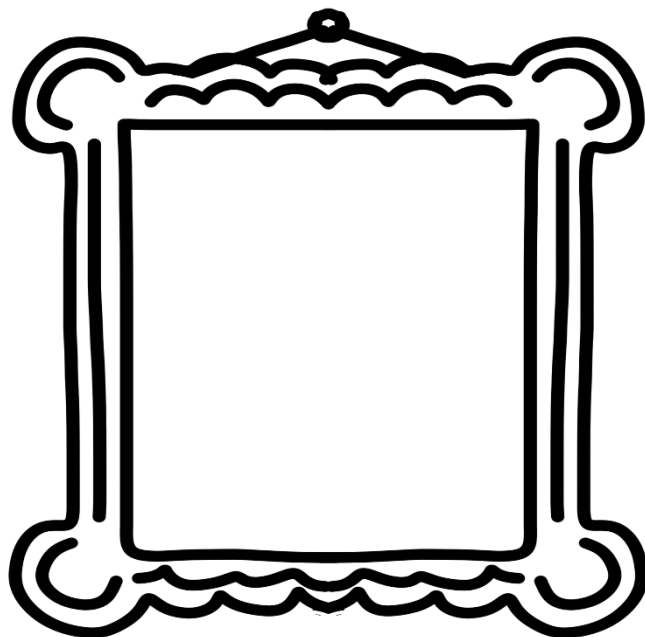

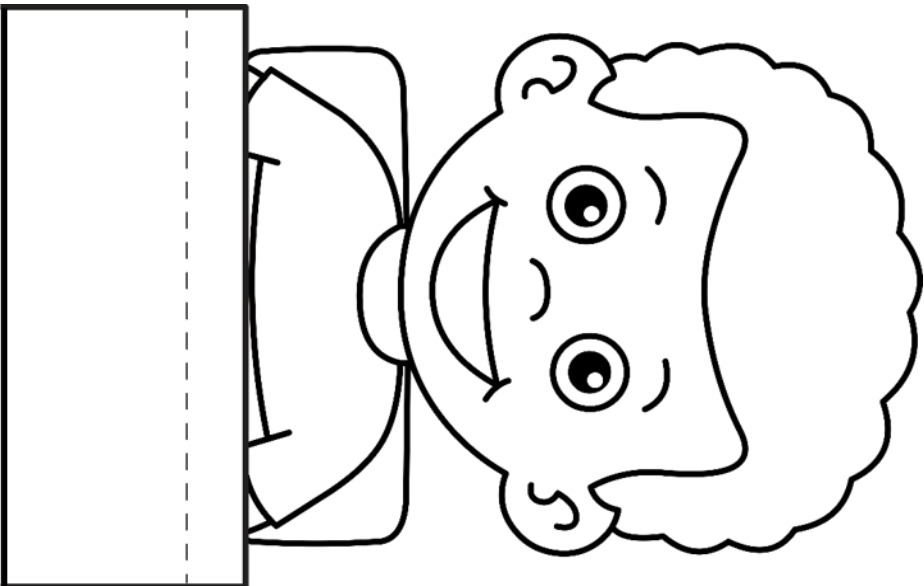
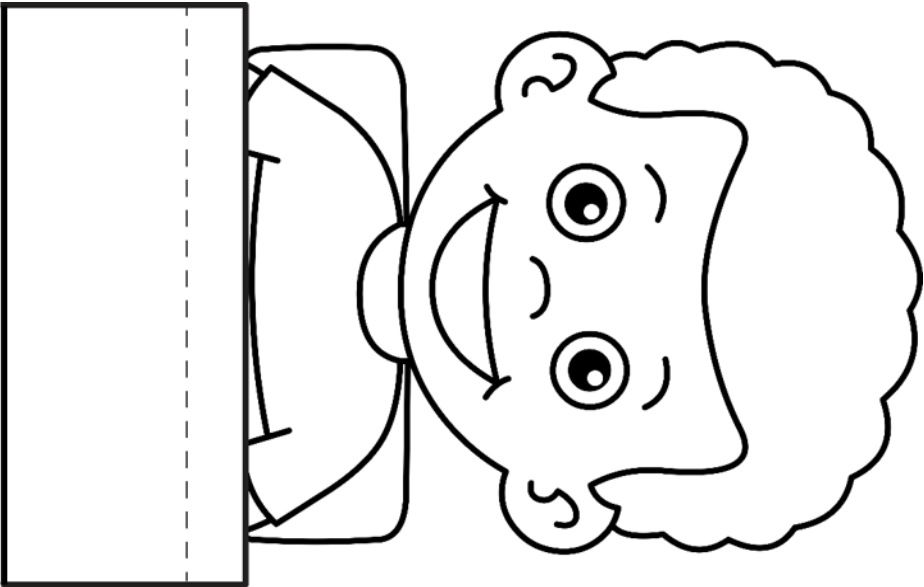
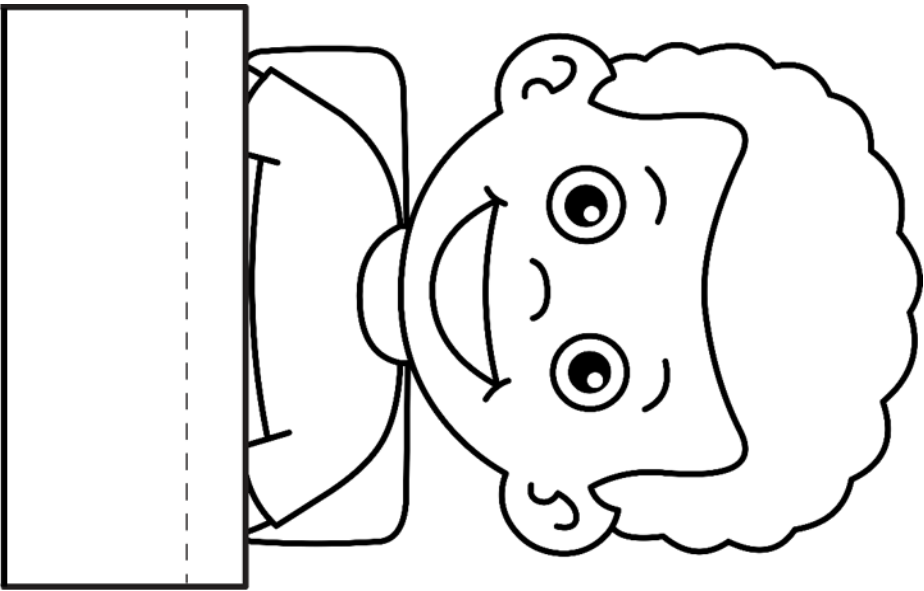

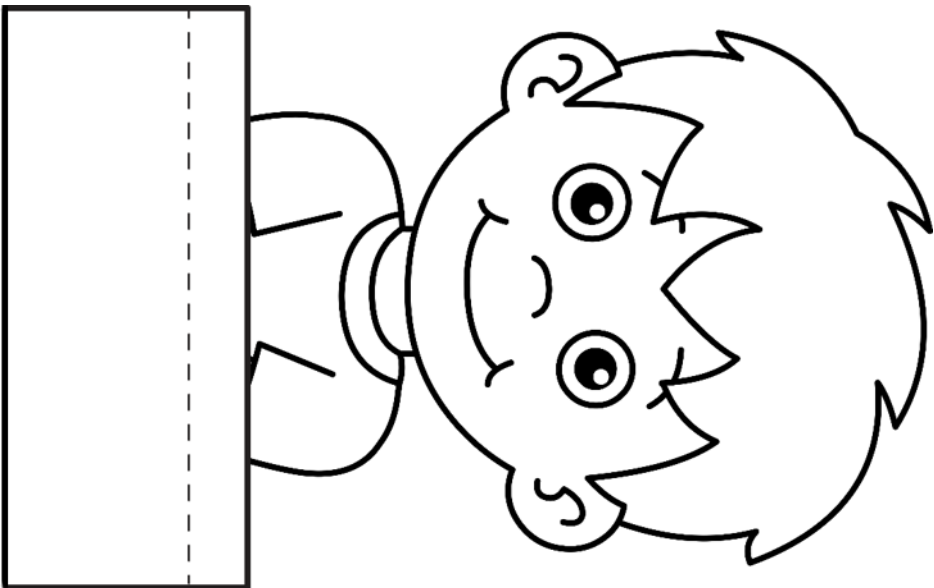
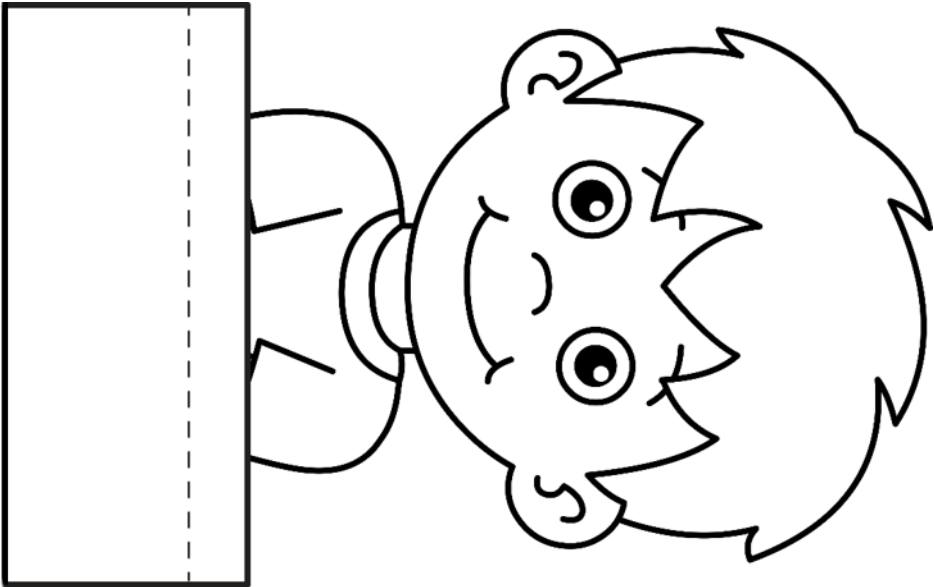
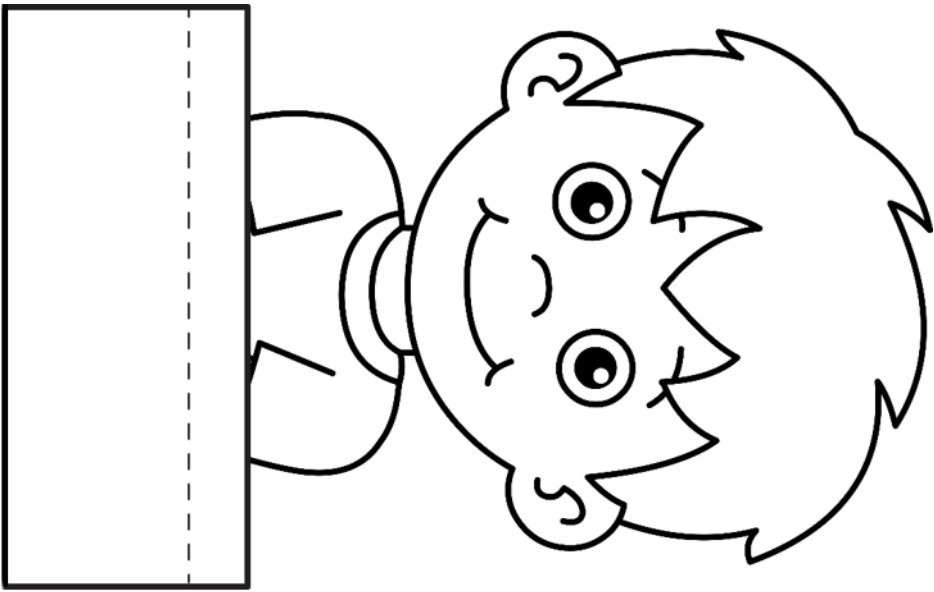

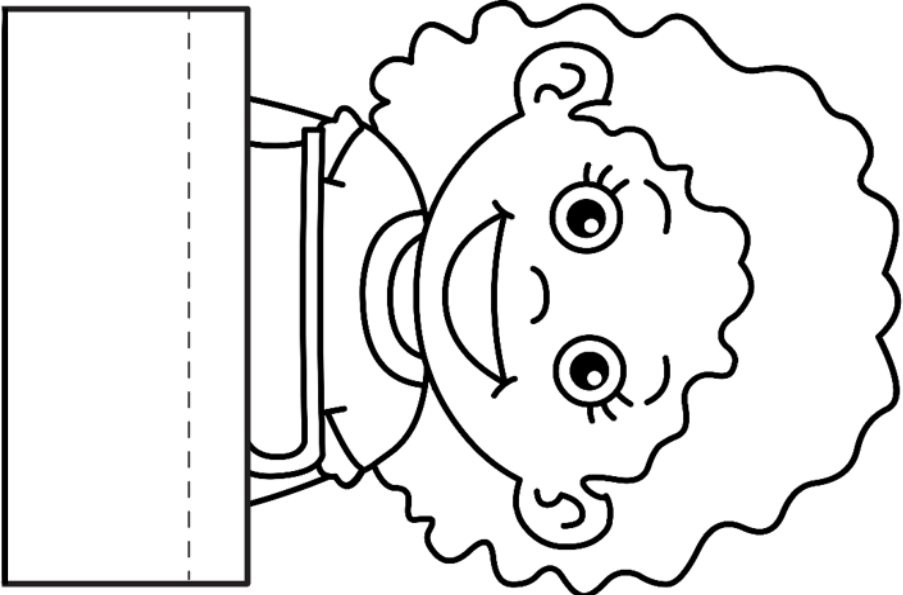
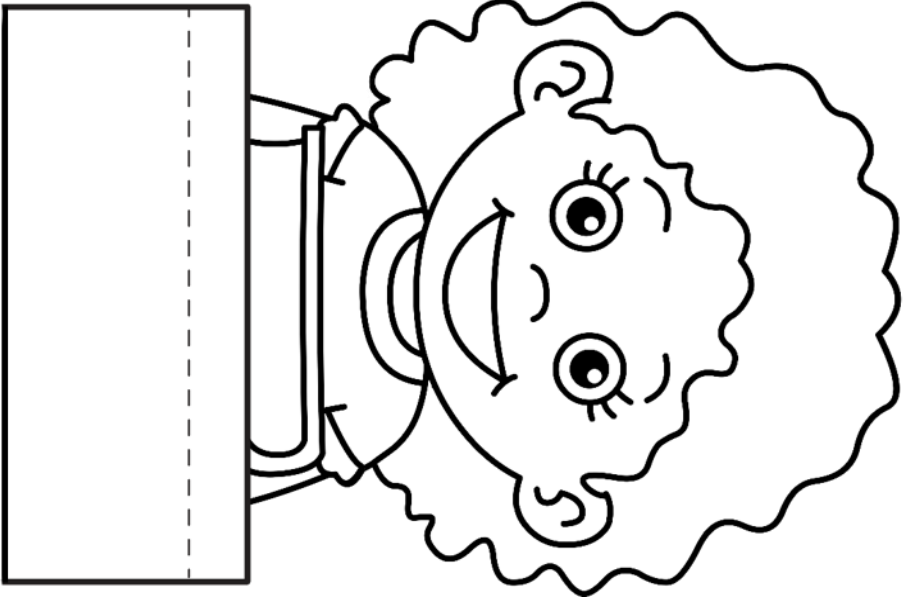
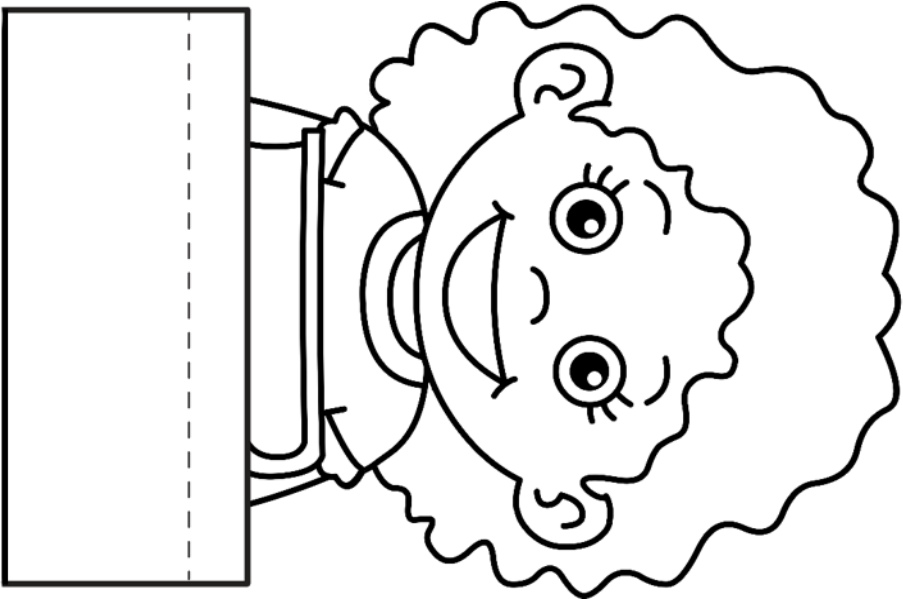

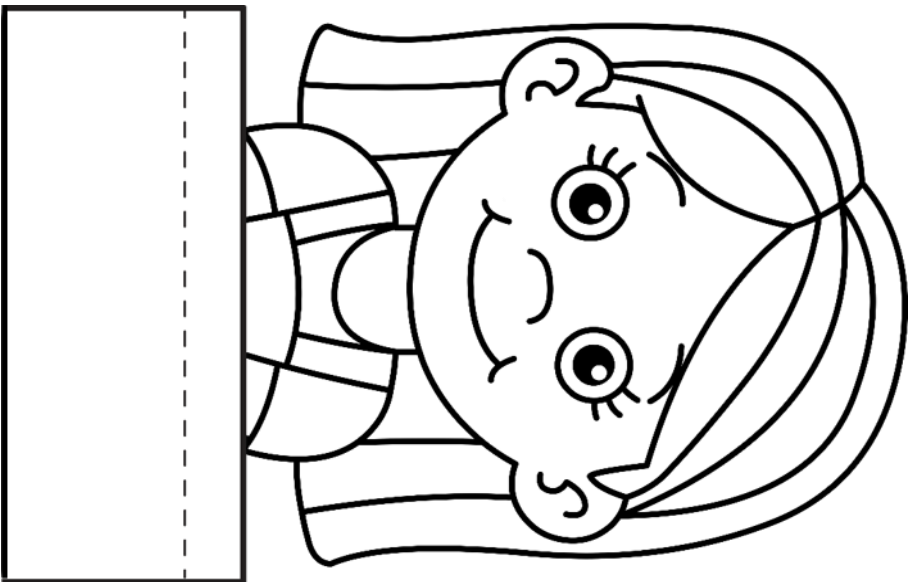
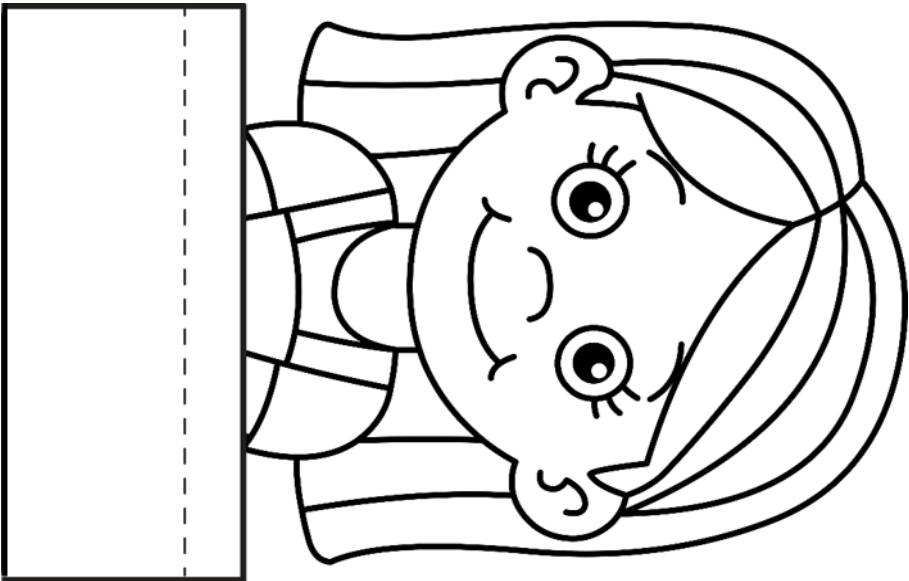
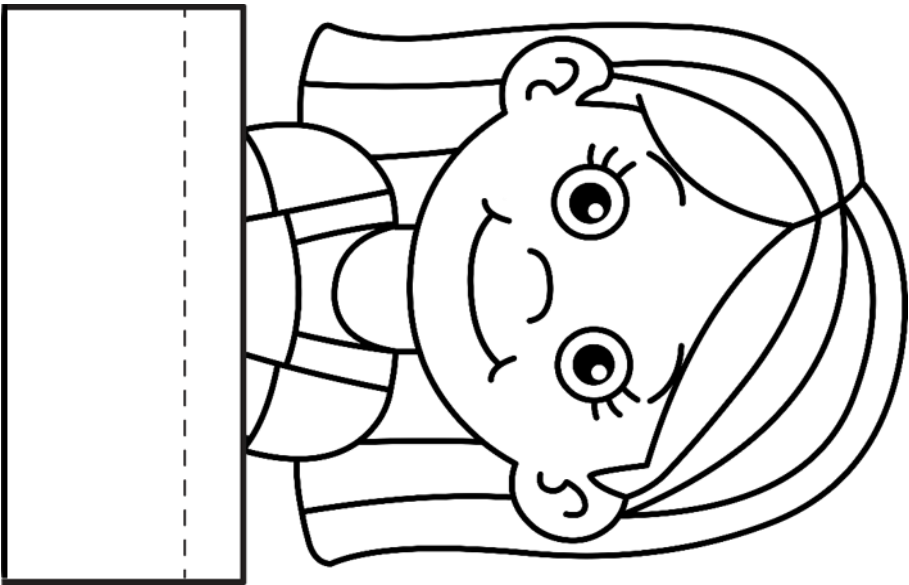



"My Super Words" Flaps

1. Glue "My Super Words" Base Page - with flaps flat into the notebook.

2. Fold at the dotted line on the flaps found on this page.

3. Apply glue on the back side above the dotted line & secure on top of indicated markers on base page.

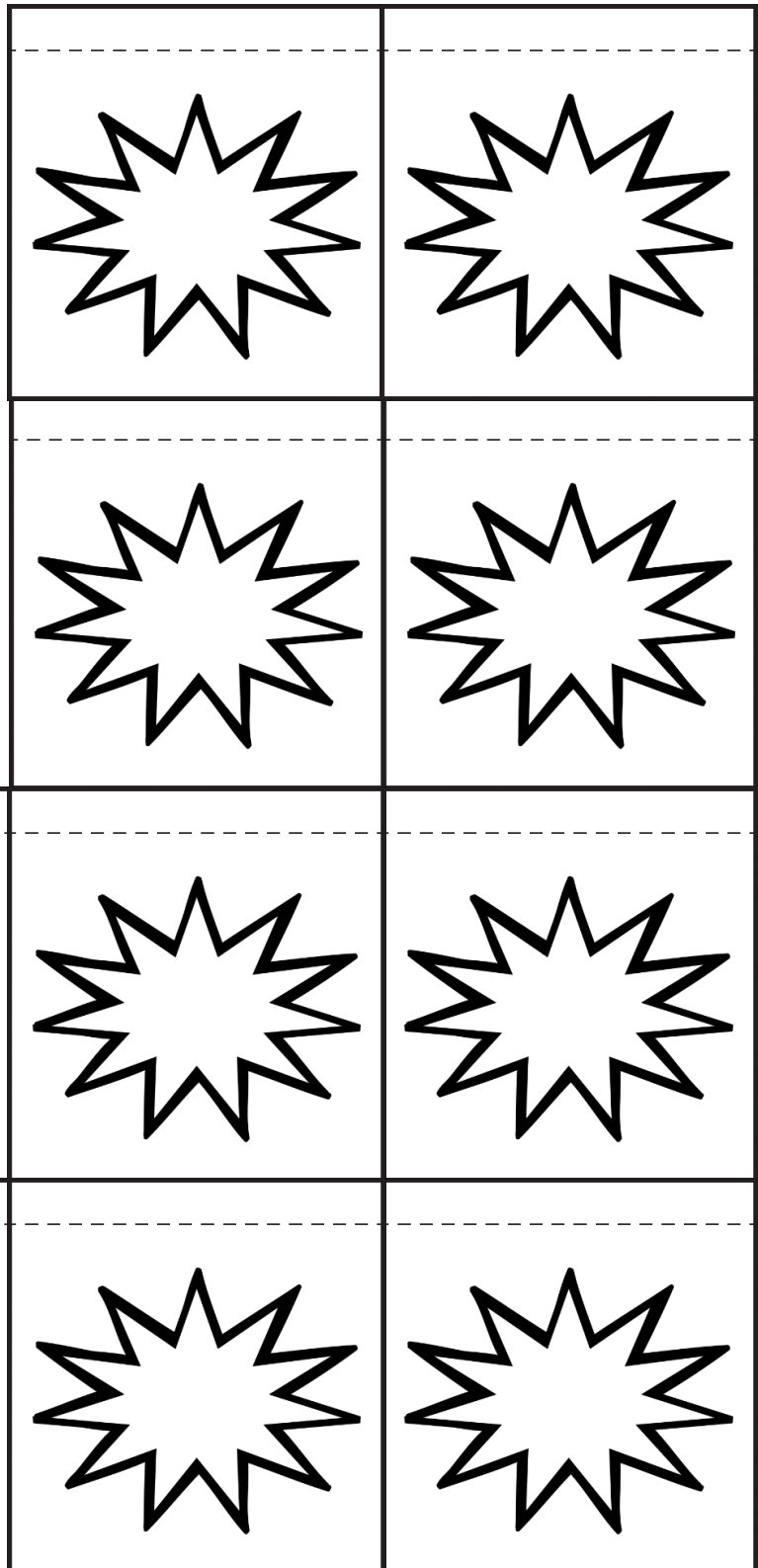

"My Super Words" Base Page - with flaps

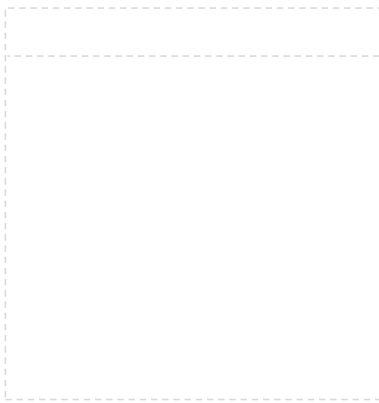
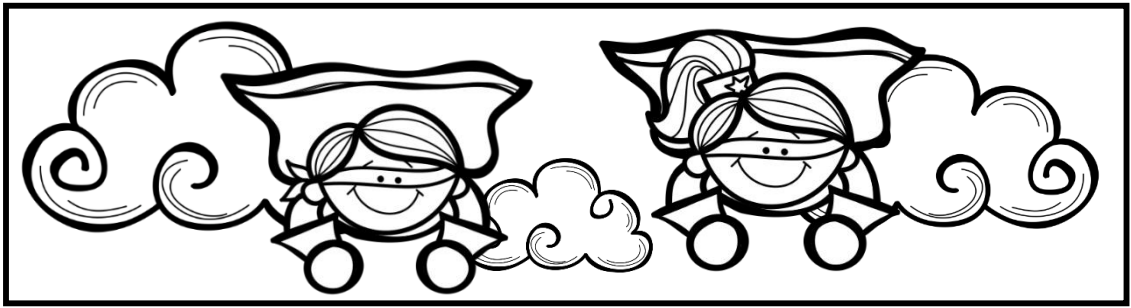

"My Super Words" Base Page - no flaps

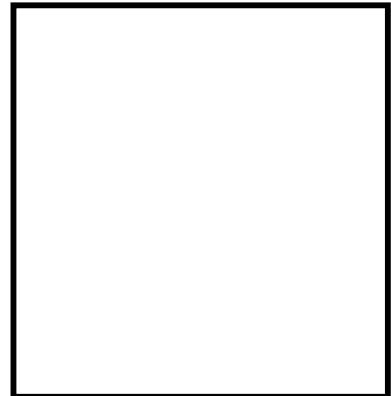
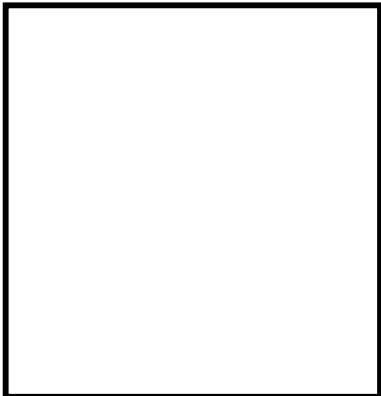
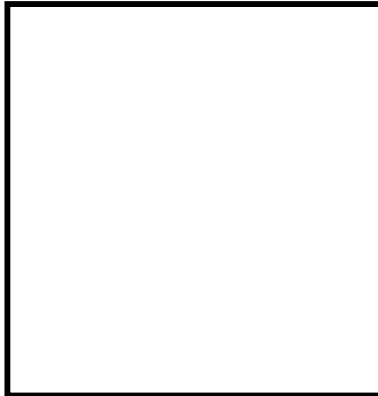
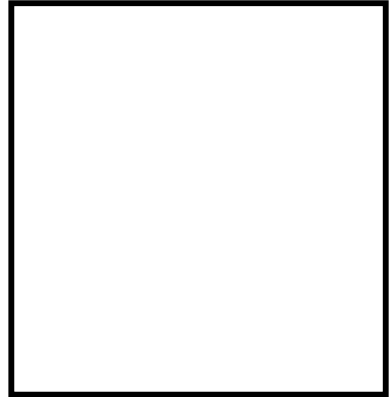
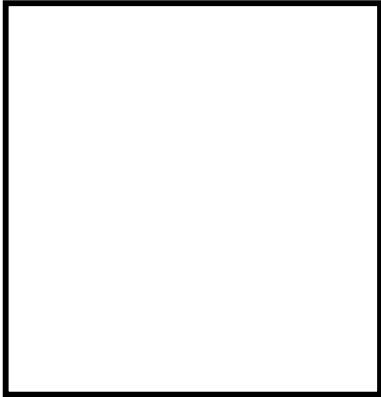
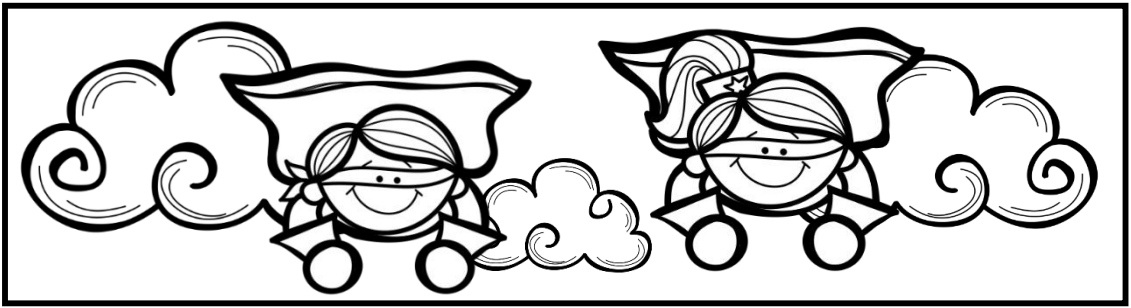

Cut out pages & glue page 1 into the lap book.

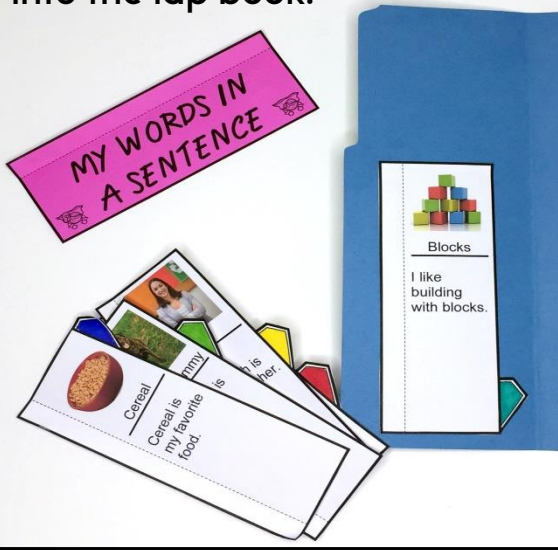

Glue page 2 on top.

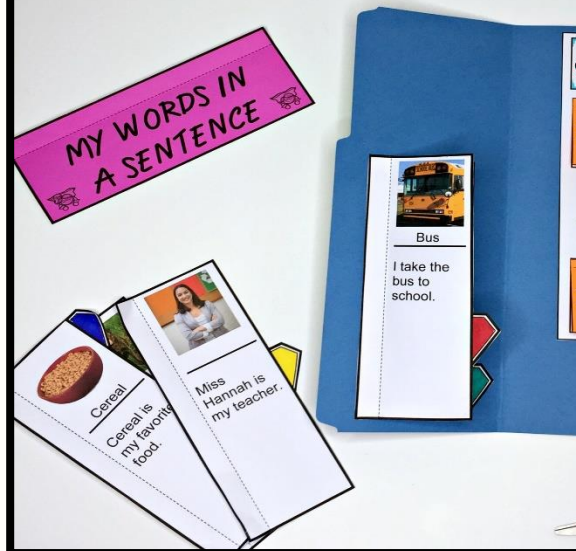

Continue layering one on top of the other until all pages are in the lap book.

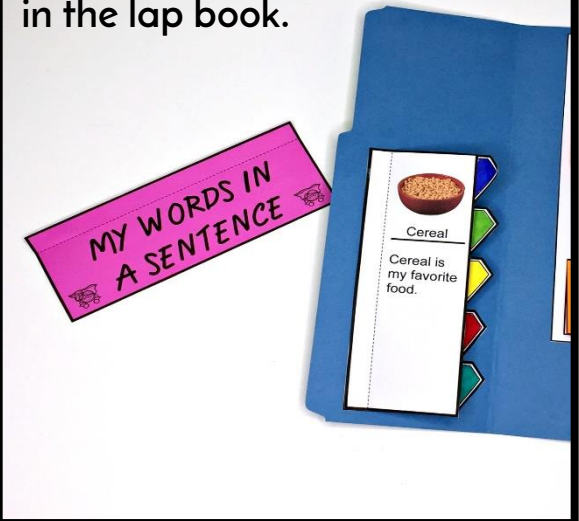

Glue the cover on last.



Enjoy!



This activity also works great as a take-home review flipbook. Print the pages on durable cardstock and cut. Align the straight edges together & staple to create your booklet.

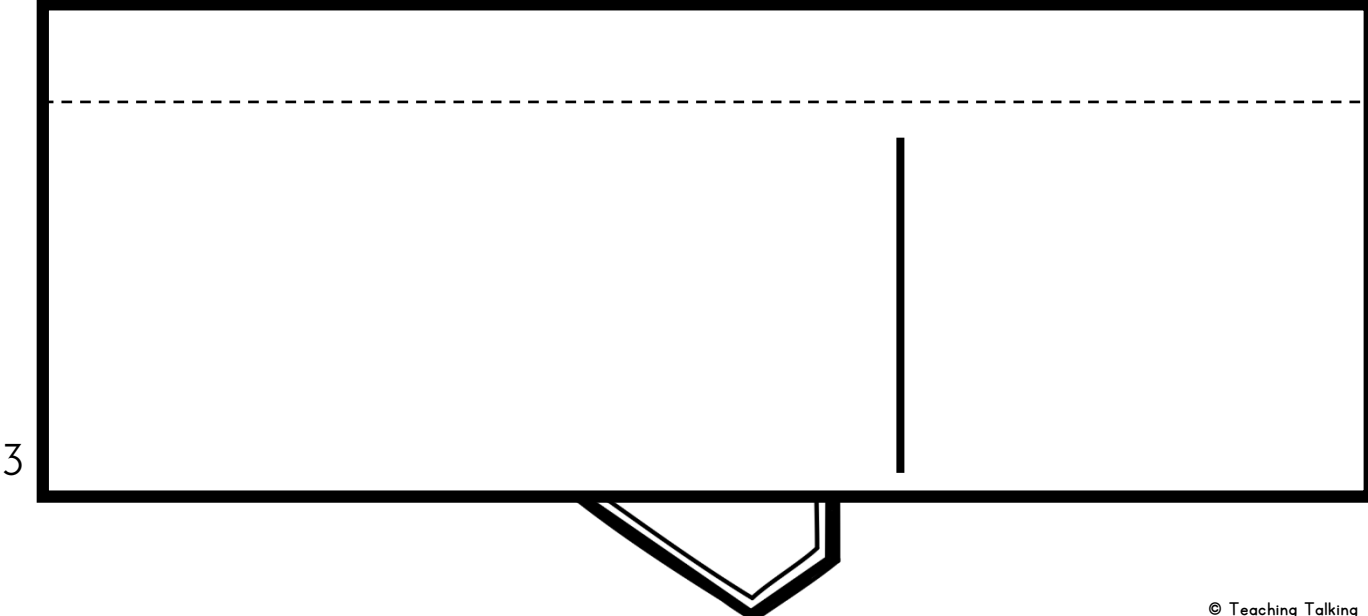
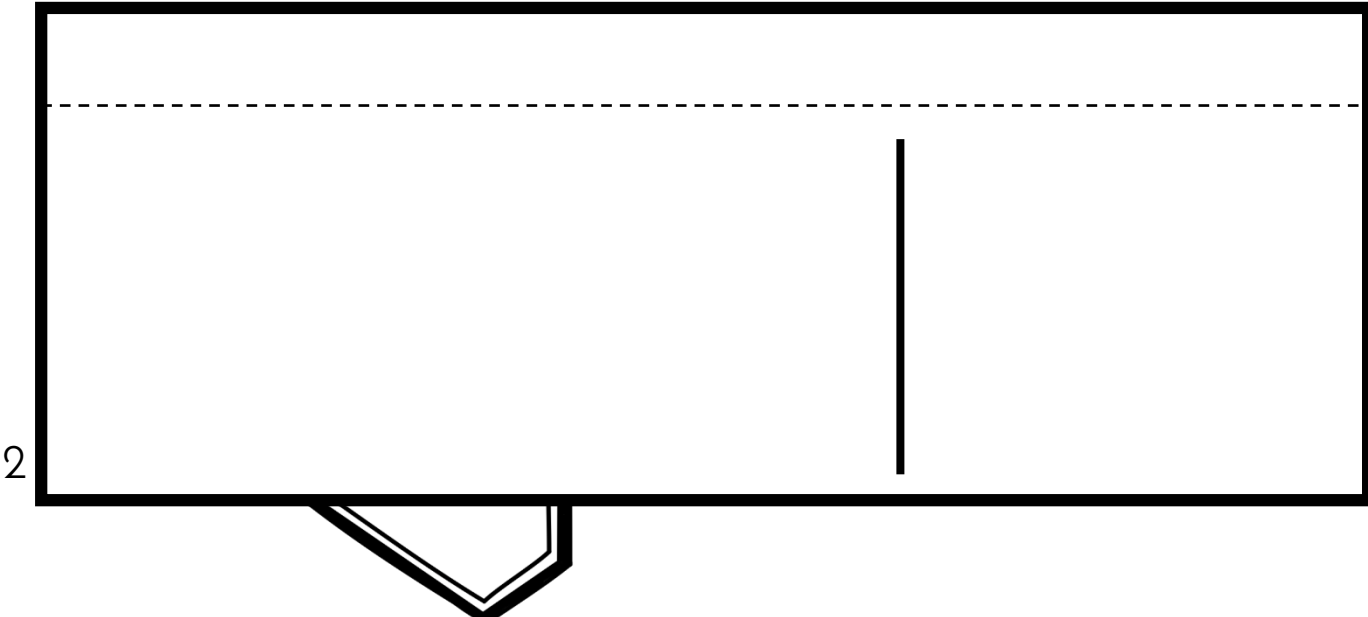
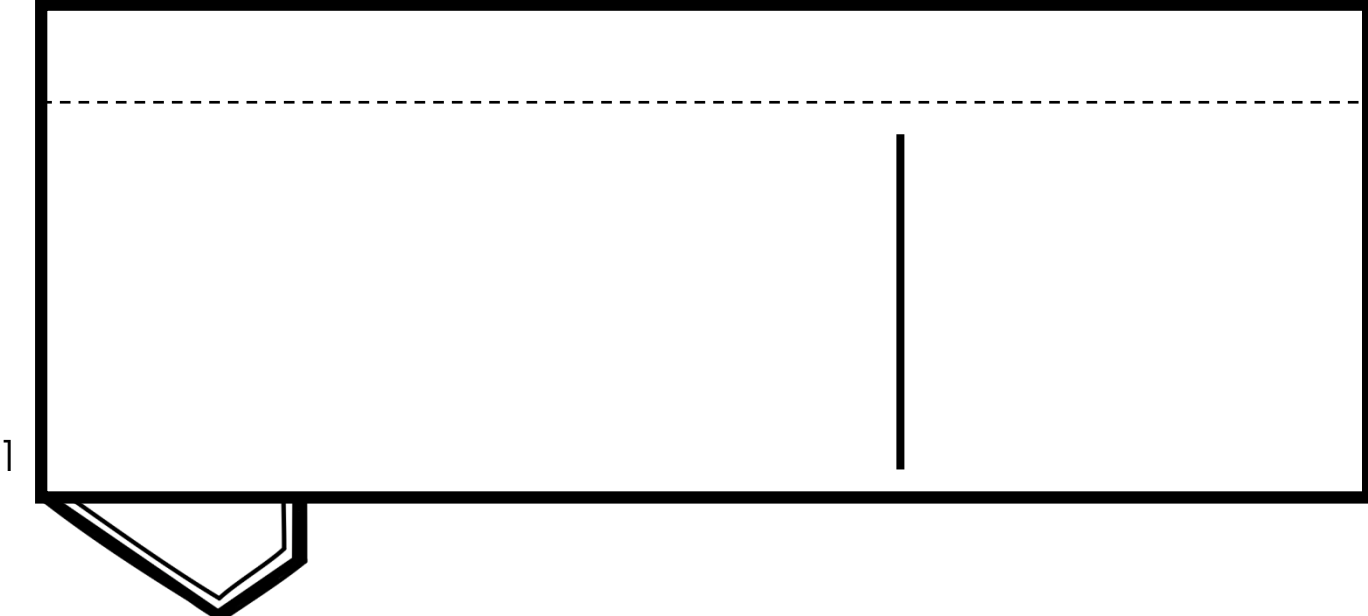

4

Blank handwriting practice box with a dashed top line and a vertical midline.

5

Blank handwriting practice box with a dashed top line and a vertical midline.

6

*MY WORDS IN
A SENTENCE*



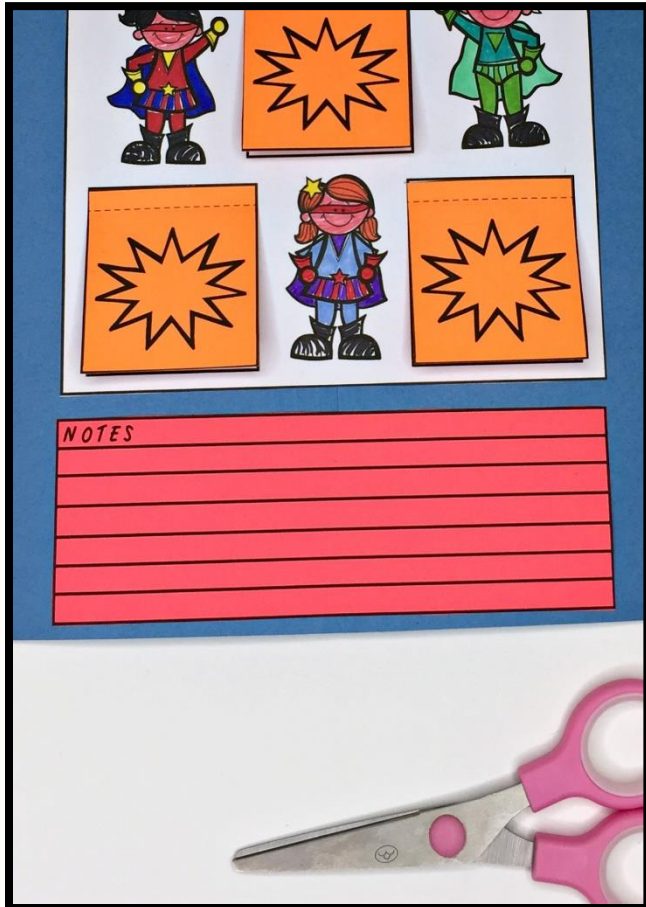
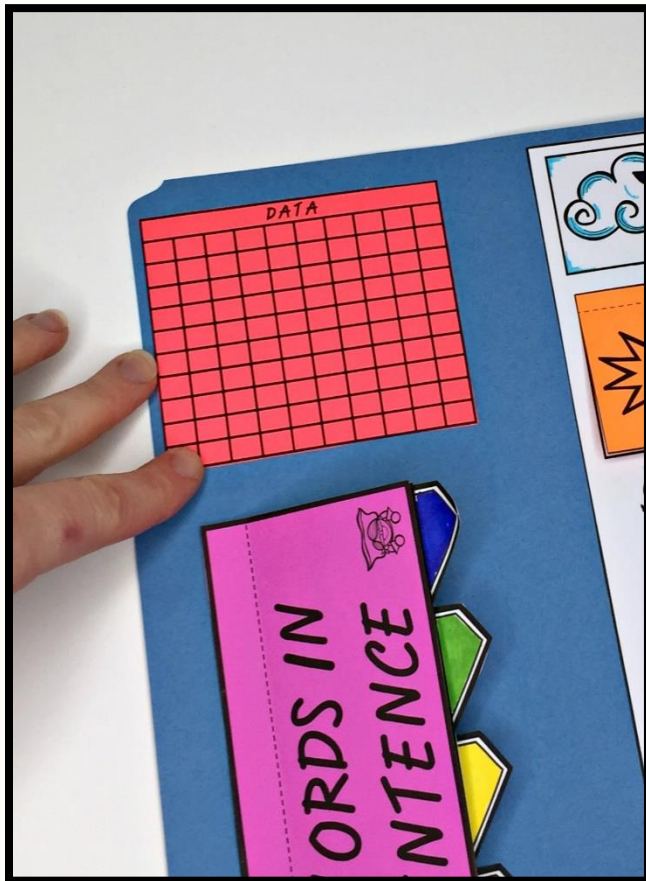

1. Cut around outer edge of the grid and glue it into your notebook.
2. Use it to keep track of target repetitions.

<i>DATA</i>									

1. Cut around outer edge of the grid and glue it into your notebook.
2. Use it to record SLP notes or instructions.

<i>NOTES</i>